

WORKING COPY
THROWN AWAY AFTER USE

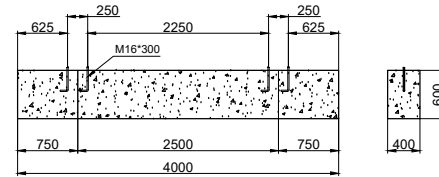
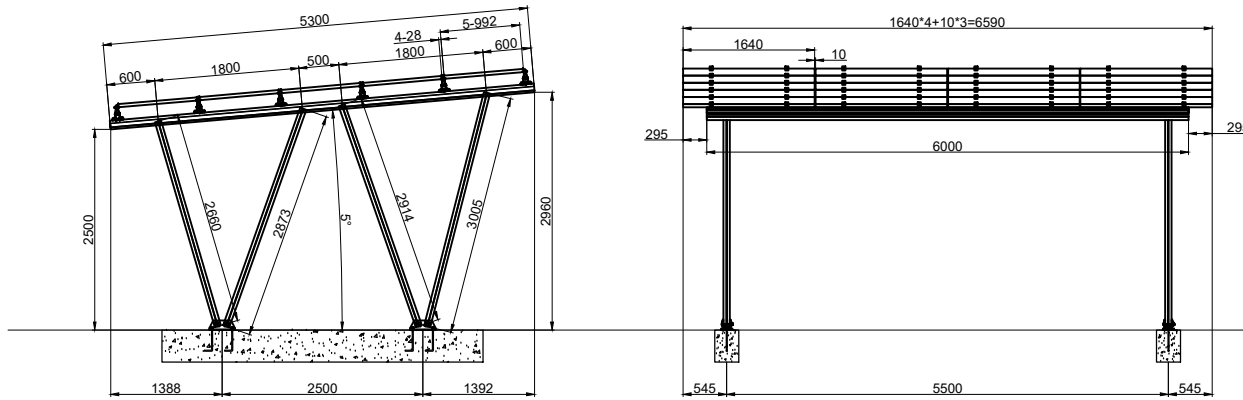

6	UN-IC-40	L40 5A	32	AI 6005-T5
5	UN-EC-40	L40 5A	16	AI 6005-T5
4	UN-RC11-SPLICE	L400	0	AI 6005-T5
3	UN-RC-11	L6000	6	AI 6005-T5
2	UN-Clamp-F	L40	48	AI 6005-T5
1	UN-STC-R110	L5300	2	AI 6005-T5
Item	Part Name	Spec.	Qty	Material

N.S.T	Chris	Car Park System	Weight	kg
Date 2018-04-09	App by	Module Size: 1640*992*40 mm 5*4 PCS / SET	Code	Sheet of
Solar Land Energy		Wind Load: 40 m/s Snow Load: / cm	Draw. no.	Rev.
			UI-180402-002A	

No	Changes and/or note no.-nr	Date	Change By
B			